



# Solar Inverter

## On-Grid | Off-Grid USER MANUAL



PV Input Power  
9000Watt



Voltage Range  
60 ~ 500VDC



ON || OFF  
GRID

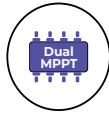

Dual  
MPPT



AC Output  
6000Watt



Pure Sine  
Wave



Real Time  
Sharing

**ENVY 9000**

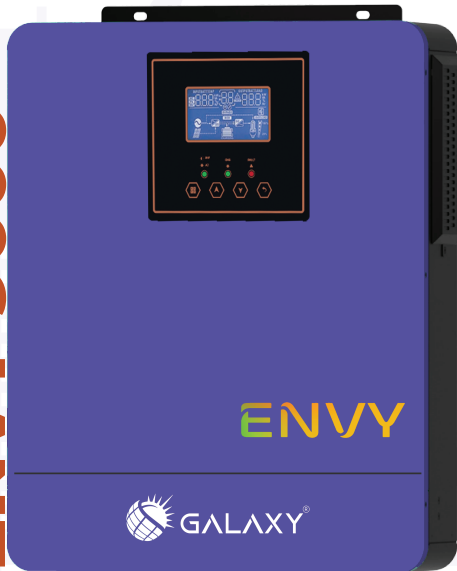

**1YEAR WARRANTY**

# TABLE OF CONTENTS

<b>1.ABOUT THIS MANUAL</b> .....	<b>02</b>
1.1 PURPOSE .....	02
1.2 SCOPE .....	02
<b>2.SAFETY INSTRUCTIONS</b> .....	<b>02</b>
<b>3.INTRODUCTION</b> .....	<b>03</b>
3.1 FEATURES .....	03
3.2 BASIC SYSTEM ARCHITECTURE .....	03
3.3 PRODUCT OVERVIEW .....	04
<b>4.INSTALLATION</b> .....	<b>05</b>
4.1 UNPACKING AND INSPECTION .....	05
4.2 PREPARATION .....	05
4.3 MOUNTING THE UNIT .....	05
4.4 AC INPUT/OUTPUT CONNECTION .....	06
4.5 PV CONNECTION .....	08
4.6 CURRENT TRANSFORMER CONNECTION .....	10
4.7 FINAL ASSEMBLY .....	10
4.8 COMMUNICATION CONNECTION .....	11
<b>5.OPERATION</b> .....	<b>11</b>
5.1 POWER ON/OFF .....	11
5.2 OPERATION AND DISPLAY PANEL .....	11
5.3 LCD DISPLAY ICONS .....	12
5.4 LCD SETTING .....	14
5.5 DISPLAY SETTING .....	17
5.6 OPERATING MODE DESCRIPTION .....	20
5.7 FAULT REFERENCE CODE .....	21
5.8 WARNING INDICATOR .....	21
<b>6.CLEARANCE AND MAINTENANCE FOR ANTI-DUST KIT</b> .....	<b>22</b>
6.1 OVERVIEW .....	22
6.2 CLEARANCE AND MAINTENANCE .....	22
<b>7.SPECIFICATIONS</b> .....	<b>23</b>
TABLE 1 LINE MODE SPECIFICATIONS .....	23
TABLE 2 INVERTER MODE SPECIFICATIONS .....	23
TABLE 3 MPPT SOLAR MODE SPECIFICATIONS .....	24
TABLE 4 GRID-TIE OPERATION (OPTIONAL) .....	24
TABLE 5 GENERAL SPECIFICATIONS .....	24
<b>8.TROUBLE SHOOTING</b> .....	<b>25</b>

# 1.ABOUT THIS MANUAL

## 1.1 Purpose

This manual describes the assembly, installation, operation and troubleshooting of this unit. Please read this manual carefully before installations and operations, Keep this manual for future reference.

## 1.2 Scope

This manual provides safety and installation guidelines as well as information on tools and wiring.

# 2.SAFETY INSTRUCTIONS

### WARNING

- This chapter contains important safety and operating instructions. Read and keep this manual for future reference.
- Only qualified service persons are able to service this device. If errors still persist after following troubleshooting table, please send this inverter/charger back to local dealer or service center for maintenance.

- 1.Before using the unit, read all instructions and cautionary markings on the unit, all appropriate sections of this manual.
- 2.Do not disassemble the unit. Take it to a qualified service center when service or repair is required .Incorrect reassembly may result in a risk of electric shock or fire.
- 3.To reduce risk of electric shock, disconnect all wirings before attempting any maintenance or cleaning. Turning off the unit will not reduce this risk.
- 4.For optimum operation of this inverter/charger, please follow required spec to select appropriate cable size. It's very important to correctly operate this inverter/charger.
- 5.Please strictly follow installation procedure when you want to disconnect AC or DC terminals. Please refer to installation section of this manual for the details.
- 6.This inverter/charger should be connected to a permanent grounded wiring system. Be sure to comply with local requirements and regulation to install this inverter.
- 7.Never cause AC output and DC input short circuited. Do not connect to the mains when DC input short circuits.

### 3. INTRODUCTION

This is a multi-function inverter/charger, combining functions of inverter, Its comprehensive LCD display offers user-configurable and easy-accessible button operation.

#### 3.1 Features

- 1.Pure sine wave inverter.
- 2.Configurable input voltage range for home appliances and personal computers via LCD setting.
- 3.Combind to the grid based on applications via LCD setting.
- 4.Compatible to mains voltage.
- 5.Auto restart while AC is recovering.
- 6.Overload/ Over temperature/ short circuit protection.
- 7.Cold start function.

#### 3.2 Basic System Architecture

The following illustration shows basic application for this inverter/charger. It also includes following devices to have a complete running system:

- 1.Generator or Utility.
- 2.PV modules.

Consult with your system integrator for other possible system architectures depending on your requirements.This inverter can power all kinds of appliances in home or office environment, including motor-type appliances such as tube light, fan, refrigerator and air conditioner.

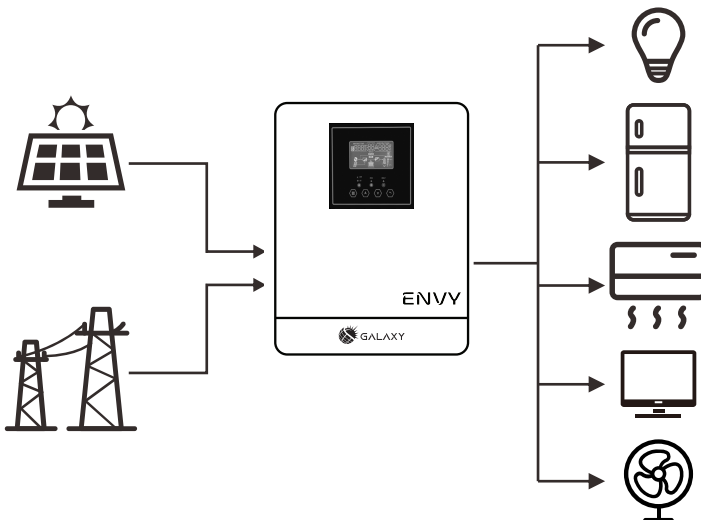

### 3.3 Product Overview

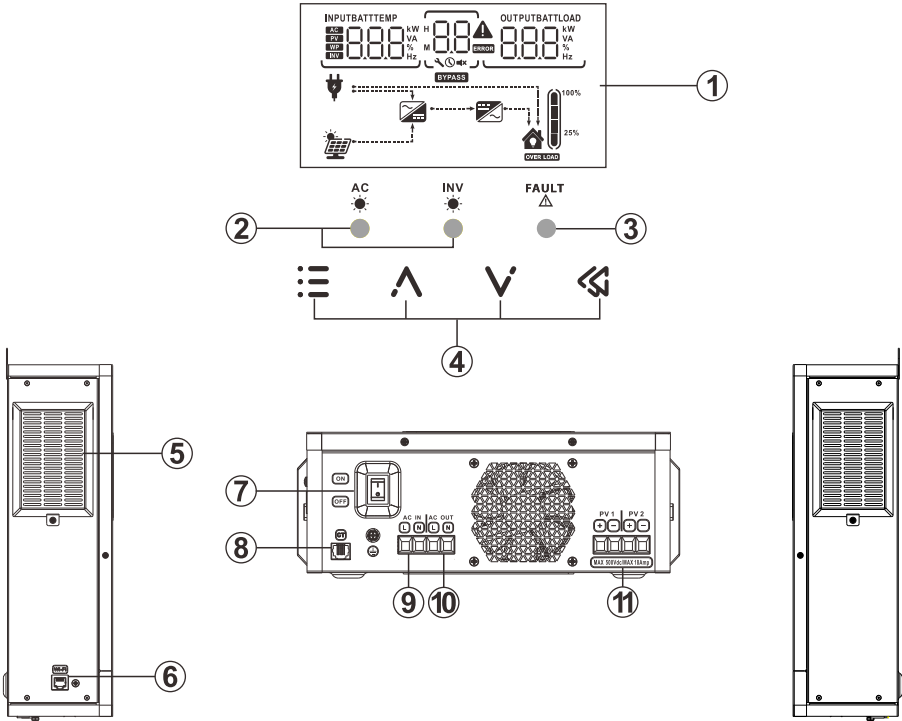

- |                                   |                        |
|-----------------------------------|------------------------|
| 1. LCD display                    | 7. Power on/off switch |
| 2. Status indicator               | 8. Current Transformer |
| 3. Fault indicator                | 9. AC input            |
| 4. Function buttons               | 10. AC out             |
| 5. Anti dust kit                  | 11. PV input           |
| 6. WIFI communication/RS-232 port |                        |

## 4 INSTALLATION

### 4.1 Unpacking And Inspection

Before installation, please inspect the unit. Be sure that nothing inside the package is damaged. You should have received the following items inside of package:

- ▶ The unit x 1
- ▶ User manual x 1
- ▶ Current Transformer x 1 (optional)
- ▶ WIFI x 1 (optional)

### 4.2 Preparation

Before connecting all lines, remove the screws under the machine and remove the bottom cover plate.

### 4.3 Mounting The Unit

Consider the following points before selecting where to install:

1. Do not mount the inverter on flammable construction materials.
2. Mount on a solid surface.
3. Install this inverter at eye level in order to allow the LCD display to be read at all times.
4. For proper air circulation to dissipate heat, allow a clearance of approx. 20 cm to the side and approx. 50 cm above and below the unit.
5. The ambient temperature should be between 0°C and 55°C to ensure optimal operation.
6. The recommended installation position is to be adhered to the wall vertically.
7. Make sure that other objects and surfaces are left with enough space from the machine to ensure adequate heat dissipation and that there is enough room to remove the wires.

 **CAUTION**

- Suitable for mounting on concrete or other non-combustible surface only.

Install the unit by screwing two screws. It's recommended to use M4 or M5 screws.

## 4.4 AC Input/Output Connection

### CAUTION

- Before connecting to AC input power source, please install a separate AC breaker between inverter and AC input power source. This will ensure the inverter can be securely disconnected during maintenance and fully protected from over current of AC input. The recommended spec of AC breaker is 32A for 4KW, 50A for 6KW, and 85A for 10KW.
- There are two terminal blocks with "IN" and "OUT" markings. Please do NOT mis-connect input and output connectors.

### WARNING

- All wiring must be performed by a qualified personnel.
- It's very important for system safety and efficient operation to use appropriate cable for AC input connection. To reduce risk of injury, please use the proper recommended cable size as below.

Please follow below steps to implement AC input/output connection:

1. Before making AC input/output connection, be sure to open DC protector or disconnect first.
2. Remove insulation sleeve 10mm for six conductors. And shorten phase L and neutral conductor N3 mm.
3. Insert AC input wires according to polarities indicated on terminal block and tighten the terminal screws.

L→LINE(brown or black)

N→Neutral(blue)

⊕ →Ground (green&yellow)

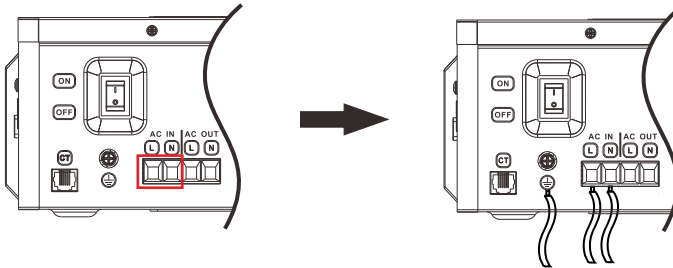

**⚠ WARNING**

- Be sure that AC power source is disconnected before attempting to hardwire it to the unit.

4. Then, insert AC output wires according to polarities indicated on terminal block and tighten terminal screws.

L→LINE(brown or black)

N→Neutral(blue)

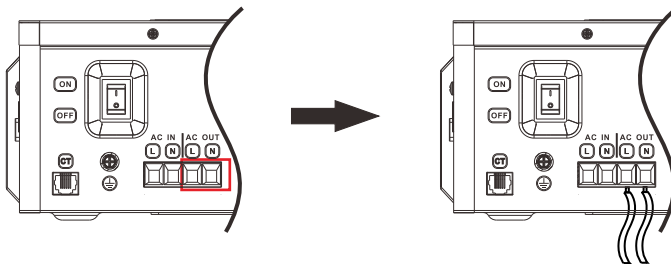

5. Make sure the wires are securely connected.

**⚠ CAUTION**

- Appliances such as air conditioner are required at least 2~3 minutes to restart because it's required to have enough time to balance refrigerant gas inside of circuits. If a power shortage occurs and recovers in a short time, it will cause damage to your connected appliances. To prevent this kind of damage, please check manufacturer of air conditioner if it's equipped with time-delay function before installation. Otherwise, this inverter/charger will trig overload fault and cut off output to protect your appliance but sometimes it still causes internal damage to the air conditioner.

### 4.5 PV Connection

**⚠ CAUTION**

- Before connecting to PV modules, please install separately a DC circuit breaker between inverter and PV modules.

**⚠ WARNING**

- It's very important for system safety and efficient operation to use appropriate cable for PV module connection. To reduce risk of injury, please use the proper recommended cable size as below.

Model	Wire size	Cable(mm <sup>2</sup> )	Torque value(max)
4KW/6KW/10KW/15KW	1×12AWG	4	1.2N · m

PV Module Selection:

When selecting proper PV modules, please be sure to consider below parameters:

- 1.Open circuit Voltage (Voc) of PV modules not exceeds max. PV array open circuit voltage of inverter.
- 2.Open circuit Voltage (Voc) of PV modules should be higher than 150V.

Inverter Model	4KW/6KW/10KW/15KW
Max. PV Array Open Circuit Voltage	500Vdc
PV Array MPPT Voltage Range	60Vdc~450Vdc

Take 650Wp PV module as an example. After considering above two parameters, the recommended module configurations are listed as below table.

Solar Panel Spec. (reference)	Solar input	Q'ty of panels	Total input power
	(Min in serial: 3 pcs, max. in serial: 9 pcs)		
-650Wp			
-Vmp: 44.33V	3 pcs in serial	3 pcs	1950W
-Imp: 14.64A	7 pcs in serial	7 pcs	4500W
-Voc: 52.93V	9 pcs in serial	9 pcs	5840W
-Isc: 15.37A			
-Cells:288(144×2)	7 pieces in serial and 2 sets in parallel	14 pcs	9000W

	9 pieces in serial and 2 sets in parallel	18 pcs	11680W
	7 pieces in serial and 3 sets in parallel	21 pcs	13500W

PV Module Wire Connection

Please follow below steps to implement PV module connection:

- 1.Remove insulation sleeve 10 mm for positive and negative conductors.
- 2.Suggest to put bootlace ferrules on the end of positive and negative wires with a proper crimping tool.

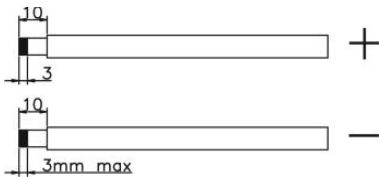

3. Check correct polarity of wire connection from PV modules and PV input connectors. Then, connect positive pole (+) of connection wire to positive pole (+) of PV input connector. Connect negative pole (-) of connection wire to negative pole (-) of PV input connector. Recommended tool: 4mm blade screwdriver.

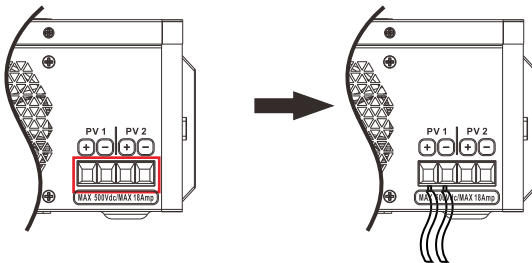

\*This diagram uses a 6KW machine as an example. 4KW machine is single PV, 6KW machine is dual PV, 10KW machine is three PV and 15KW machine is four PV.

### 4.6 Current Transformer Connection

Connect the CT connector at the bottom of the machine. Connect the left terminal to the positive terminal and the right terminal to the negative terminal.

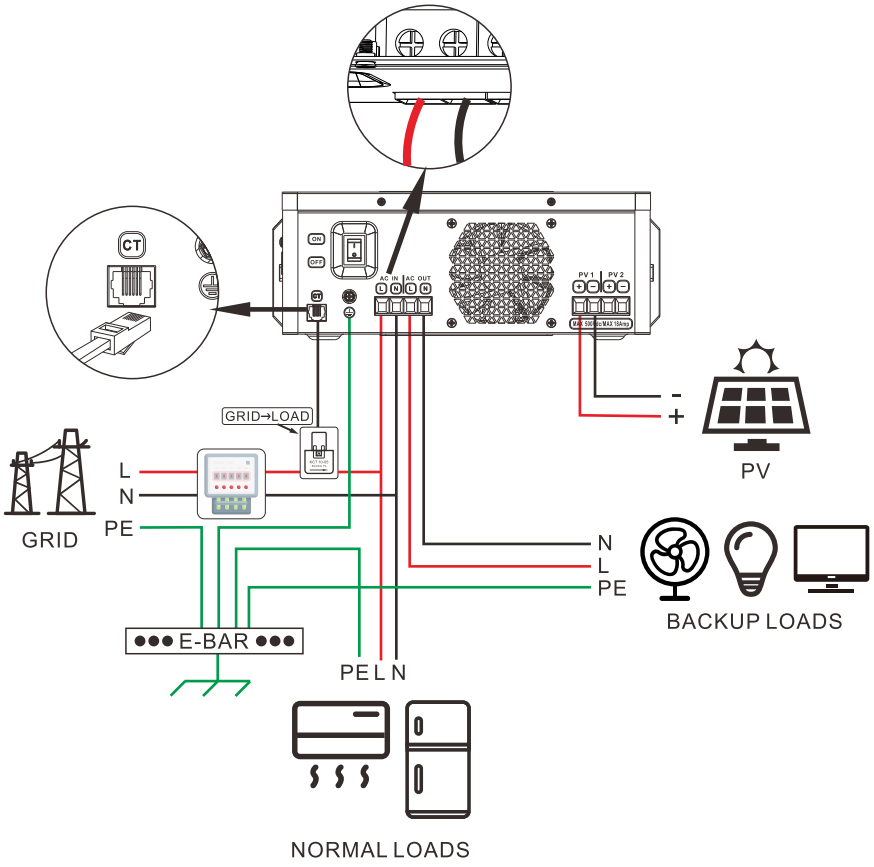
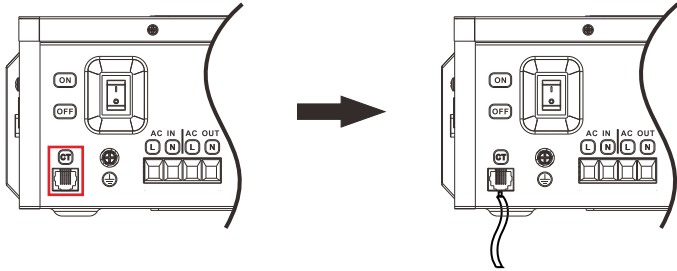

### 4.7 Final Assembly

After connecting all wirings, please put bottom cover back by screwing two screws as shown below.

## 4.8 Communication Connection

### 1. Wi-Fi cloud communication(option):

Please use supplied communication cable to connect to inverter and Wi-Fi module. Download APP and installed from APP store, and refer to "Wi-Fi Plug Quick Installation Guideline" to set up network and registering. The inverter status would be shown by mobile phone APP or webpage of computer.

## 5 OPERATION

### 5.1 Power ON/OFF

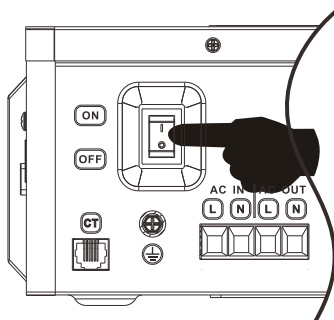

Once the unit has been properly installed, simply press on switch(located on the button of the case) to turn on the unit.

### 5.2 Operation And Display Panel

The operation and display panel, shown in below chart, is on the front panel of the inverter. It includes second indicators, four function keys and a LCD display, indicating the operating status and input/output power information.

#### LED Indicator

LED Indicator			Messages
AC ☀️	Green	Solid On	Output is powered by utility in Line mode.
INV ☀️	Green	Solid On	Output is powered by PV.
FAULT ⚠️	Red	Solid On	Fault occurs in the inverter.
		Flashing	Warning condition occurs in the inverter.

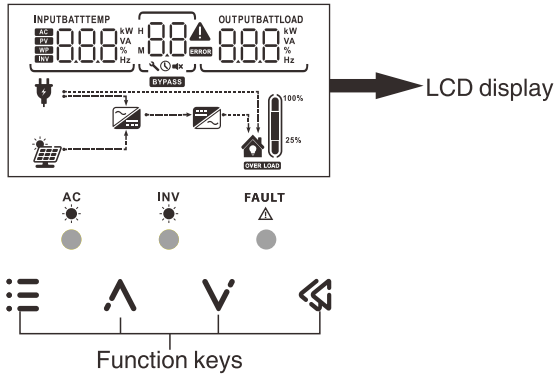







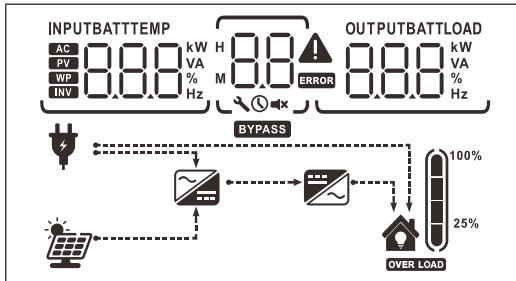



Function keys

Function key	Description
ESC	To exit setting mode
UP	To go to previous selection
DOWN	To go to next selection
ENTER	To confirm the selection in setting mode or enter setting mode

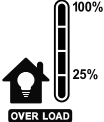
### 5.3 LCD Display Icons



Icon	Function description
Input Source Information	
	Indicates the AC input.
	Indicates the PV input

	<p>Indicate input voltage, input frequency, PV voltage, PV power.</p>
<p>Configuration Program and Fault Information</p>	
	<p>Indicates the setting programs.</p>
	<p>Indicates the warning and fault codes.                  Warning: 88 ▲ flashing with warning code.                  Fault: 88 ERROR lighting with fault code.</p>
<p>Output Information</p>	
	<p>Indicate output voltage, output frequency, load percent, load in VA, load in Watt.</p>
<p>Load Information</p>	
	<p>Indicates overload.</p>
<p>Mode Operation Information</p>	
	<p>Indicates unit connects to the mains.</p>
	<p>Indicates unit connects to the PV panel.</p>
	<p>Indicates load is supplied by utility power.</p>
	<p>Indicates the DC/AC inverter circuit is working.</p>
<p>Mute Operation</p>	
	<p>Indicates unit alarm is disabled.</p>

### 5.4 LCD Setting

After pressing and holding ENTER button for 3 seconds, the unit will enter setting mode. Press "UP" or "DOWN" button to select setting programs. And then, press "ENTER" button to confirm the selection or ESC button to exit.

Setting Programs:

Program	Description	Selectable option	
00	Exit setting mode	Escape (default) 00 00E	One-button restore setting options.
		00 00H	
01	Output source priority: To configure load power source priority	Utility first (default) 01 US	Utility will provide power to the loads as first priority. Solar will provide power to the loads only when utility power is not available.
		Solar first 01 SU	Solar energy provides power to the loads as first priority. If solar energy is not sufficient to power all connected loads, utility will supply power to the loads at the same time. -Solar energy and utility is not available. - Solar energy is not sufficient and utility is not available.
03	AC input voltage range	Appliances (default) 03 APPL	If selected, acceptable AC input voltage range will be within 90-280Vac.
		UPS 03 UPS	If selected, acceptable AC input voltage range will be within 170-280Vac.
06	Auto restart when overload occurs	Restart disable (default) 06 LFD	Restart enable 06 LFE
07	Auto restart when over temperature occurs	Restart disable (default) 07 LFD	Restart enable 07 LFE
09	Output frequency	50Hz(default) 09 50 <sub>Hz</sub>	60Hz 09 60 <sub>Hz</sub>

10	Output voltage	220V 10 220 <sup>v</sup>	230V(default) 10 230 <sup>v</sup>	240V 10 240 <sup>v</sup>
18	Alarm control	Alarm on (default) 18 60N	When the buzzer beeps for more than 90 seconds without action, it will automatically turn off.	
		Alarm off 18 60F		
19	Auto return to default display screen	Return to default display screen (default) 19 E5P	If selected, no matter how users switch display screen, it will automatically return to default display screen (Input voltage/output voltage) after no button is pressed for 1 minute.	
		Stay at latest screen 19 FEP	If selected, the display screen will stay at latest screen user finally switches.	
20	Backlight control	Backlight on (default) 20 LON	Backlight off 20 LOF	
22	Beeps while primary source is interrupted	Alarm on (default) 22 AON	Alarm off 22 AOF	
23	Overload bypass: When enabled, the unit will transfer to line mode if overload occurs in PV mode.	Bypass disable (default) 23 bYd	Bypass enable 23 bYE	
25	Record fault code	Record enable (default) 25 FEN	Record disable 25 FdS	
37	GRID-tie operation	Off-grid (default) 37 OFF	Inverter operates only in off-grid mode. Solar energy provides power to the loads.	
		Hybrid 37 HYd	Inverter operates hybrid mode. Solar energy provides power to the loads as first priority and charging second Excess energy feed to grid.	
38	GRID-tie current	2A(default) 38 02 <sup>A</sup>	The current options for the 6KW model are 2A, 10A and 20A. The current options for the 10KW model are 2A, 20A and 30A.	

39	Led pattern light	Led pattern on (default) 39 LON		Led pattern off 39 LOF		
40	CT	CT off(default) 40 CEE		CT on 40 CEEd		
81	Time setting-Year	YER 81 25	YER 81 26	.....	YER 81 98	YER 81 99
82	Time setting-Month	MON 82 01	MON 82 02	.....	MON 82 11	MON 82 12
83	Time setting-Day	DAY 83 01	DAY 83 02	.....	DAY 83 30	DAY 83 31
84	Time setting-Hour	HOU 84 00	HOU 84 01	.....	HOU 84 22	HOU 84 23
85	Time setting-Minute	MIN 85 00	MIN 85 01	.....	MIN 85 58	MIN 85 59
86	Clear Energy	86 d15 (default)			86 EN	

### 5.5 Display Setting

The LCD display information will be switched in turns by pressing “UP” or “DOWN” key. The selectable information is switched as below order: input voltage/output voltage, input frequency, PV voltage, PV input current, PV input power, output frequency, load percentage, load in VA, load in Watt, Daily power generation, Monthly power generation, Gross generation, Date, Time, Model, hardware and software version numbers.

Selectable information	LCD display
Input voltage/Output voltage (Default Display Screen)	Input voltage=230V, Output voltage=230V 
Input frequency	Input frequency=50Hz 
PV voltage	PV voltage=200 V 
PV current	PV current=18A 
PV power	PV power=3.6kW 

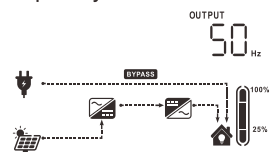
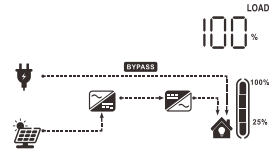
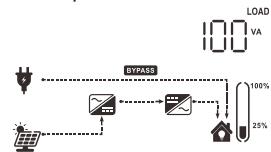
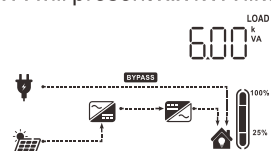
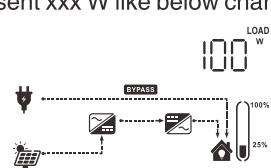
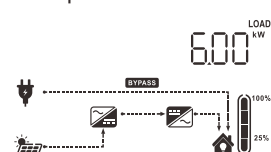
<p>Output frequency</p>	<p>Output frequency=50Hz</p> 
<p>Load percentage</p>	<p>Load percent=100%</p> 
<p>Load in VA</p>	<p>When connected load is lower than 1kVA, load in VA will present xxx VA like below chart.</p> 
	<p>When load is larger than 1kVA (<math>\geq 1\text{kVA}</math>), load in VA will present x.x kVA like below chart.</p> 
<p>Load in Watt</p>	<p>When load is lower than 1kW, load in W will present xxx W like below chart.</p> 
	<p>When load is larger than 1kW (<math>\geq 1\text{kW}</math>), load in W will present x.x kW like below chart.</p> 

<p>PV energy generation today</p>	<p>Stand by</p>	<p>0<sup>W H</sup> DAY (day)</p>
<p>PV energy generation this Month</p>	<p>Stand by</p>	<p>0<sup>W H</sup> MONTH (month)</p>
<p>Total PV energy generation</p>	<p>Stand by</p>	<p>0<sup>W H</sup> TOTAL (total)</p>
<p>Date</p>	<p>Stand by</p>	<p>25 03 01</p>
<p>Time</p>	<p>Stand by</p>	<p>08 00 00</p>
<p>Main CPU version checking</p>	<p>Main CPU version B1 06 00</p> <p>61 06 00</p>	

### 5.6 Operating Mode Description

Operation mode	Selectable information	LCD display
Operation mode	Input voltage=230V, PV voltage=210V, Output voltage=230V, Load in Watt=500W, Inv/AC(bright)	
	Input voltage=0V, PV voltage=150V, Output voltage=230V, Load in Watt=500W, Inv/AC(bright)	
	Input voltage=0V PV voltage=0V, Output voltage=0V, Load in Watt=0W,	
Line mode	Input voltage=230V, PV current=8.6A, Output voltage=230V, Load in VA=500VA, Inv/AC(bright)	
	Input voltage=230V, PV voltage=0V, Output voltage=0V, Load in Watt=0W, Inv/AC(bright)	

## 5.7 Fault Reference Code

Fault Code	Fault Event	Icon on
01	Fan is locked when inverter is off.	01 <sub>err</sub>
02	Over temperature.	02 <sub>err</sub>
05	Output short circuited or over temperature is detected by internal converter components.	05 <sub>err</sub>
06	Output voltage is too high.	06 <sub>err</sub>
07	Overload time out.	07 <sub>err</sub>
08	Bus voltage is too high.	08 <sub>err</sub>
51	Over current or surge.	51 <sub>err</sub>
52	Bus voltage is too low.	52 <sub>err</sub>
53	Inverter soft start failed.	53 <sub>err</sub>
55	Over DC voltage in AC output.	55 <sub>err</sub>
57	Current sensor failed.	57 <sub>err</sub>
58	Output voltage is too low.	58 <sub>err</sub>
59	PV voltage is over limitation.	59 <sub>err</sub>

## 5.8 Warning Indicator

Warning Code	Warning Event	Audible Alarm	Icon flashing
01	Fan is locked when inverter is on.	Beep three times every second	01▲
07	Overload.	Beep once every 0.5 second	07▲
10	Output power derating.	Beep twice every 3 seconds	10▲
15	PV energy is low.	Beep twice every 3 seconds	15▲
16	PV voltage high.	Beep twice every 3 seconds	16▲

## 6 CLEARANCE AND MAINTENANCE FOR ANTI-DUST KIT

### 6.1 Overview

Every inverter is already installed with anti-dusk kit from factory. Inverter will automatically detect this kit and activate internal thermal sensor to adjust internal temperature. This kit also keeps dusk from your inverter and increases product reliability in harsh environment.

### 6.2 Clearance and Maintenance

Step 1:

Please loosen the screw in counterclockwise direction on the top of the inverter.

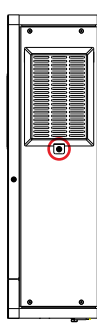

Step 2:

Then, dustproof case can be removed and take out air filter foam as shown in below chart.

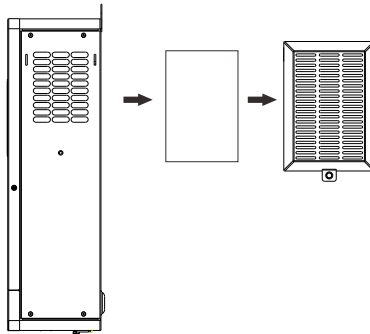

Step 3:

Clean air filter foam and dustproof case. After clearance, re-assemble the dust-kit back to the inverter

#### **NOTICE**

- The anti-dust kit should be cleaned from dust every one month.

## 7 SPECIFICATIONS

**Table 1 Line Mode Specifications**

INVERTER MODEL	4KW	6KW	10KW	15KW
Input Voltage Waveform	Sinusoidal (utility or generator)			
Nominal Input Voltage	230Vac			
Low Loss Voltage	170Vac±7V(UPS) 90Vac±7V(APL)			
Low Loss Return Voltage	180Vac±7V(UPS) 100Vac±7V(APL)			
High Loss Voltage	280Vac±7V			
High Loss Return Voltage	270Vac±7V			
Max AC Input Voltage	300Vac			
Nominal Input Frequency	50Hz/60Hz(Auto detection)			
Low Loss Frequency	40±1Hz			
Low Loss Return Frequency	42±1Hz			
High Loss Frequency	65±1Hz			
High Loss Return Frequency	63±1Hz			
Transfer Time	10ms typical (UPS)			
Output power derating: When AC input voltage drops to 170V the output power will be derated.				

**Table 2 Inverter Mode Specifications**

INVERTER MODEL	4KW	6KW	10KW	15KW
Rated Output Power	4KW	6KW	10KW	15KW
Output Voltage Waveform	Pure Sine Wave			
Output Voltage Regulation	230Vac±5%			
Output Frequency	50Hz			
Overload Protection	3s@ ≥ 150% load; 5s@ 101%~150% load			
Surge Capacity	2* rated power for 5 seconds			
No Load Power Consumption	30W	30W	35W	50W

**Table 3 MPPT Solar Mode Specifications**

MPPT Solar Mode				
INVERTER MODEL	4KW	6KW	10KW	15KW
Max.PV Array Power	4500W*1	4500W*2	4500W*3	4500W*4
Nominal PV Voltage	250Vdc			
PV Array MPPT Voltage Range	60Vdc~450Vdc			

**Table 4 Grid-Tie Operation(Optional)**

INVERTER MODEL	4KW	6KW	10KW	15KW
Nominal Output Voltage	220/230/240Vac			
Feed-in Grid Voltage Range	195Vac~253Vac			
Feed-in Grid Frequency Range	50±1Hz/60±1Hz			
Nominal Output Current	17.5A	26.5A	43.5A	65.5A
Power Factor Range	>0.99			
Maximum Conversion Efficiency (DC/AC)	97%			

**Table 5 General Specifications**

INVERTER MODEL	4KW	6KW	10KW	15KW
Safety Certification	CE			
Operating Temperature Range	-10°C ~ 50°C			
Storage Temperature	-15°C~ 60°C			
Humidity	5% to 95% Relative Humidity(Non-condensing)			

## 8 TROUBLE SHOOTING

Problem	LCD/LED/Buzzer	Explanation /Possible cause	What to do
Buzzer beeps continuously and red LED is on.	Fault code 01	Fan fault.	Replace the fan.
	Fault code 02	The inverter is overheated.	Check whether the air flow of the unit is blocked or whether the ambient temperature is too high.
	Fault code 05	Output short circuited.	Check if wiring is connected well and remove abnormal load.
	Fault code 06/58	Output abnormal. (Inverter voltage below than 190Vac or is higher than 260Vac)	1. Reduce the connectedload. 2. Return to repair center.
	Fault code 07	Overload error. The inverter is overload 102% and time is up.	Reduce the connected load by switching off some equipment.
	Fault code 08/53/57	Internal components failed.	Return to repair center.
	Fault code 51	Over current or surge.	Restart the unit, if the error happens again, please return to repair center.
	Fault code 52	Bus voltage is too low.	
Fault code 55	Output voltage is unbalanced.		